

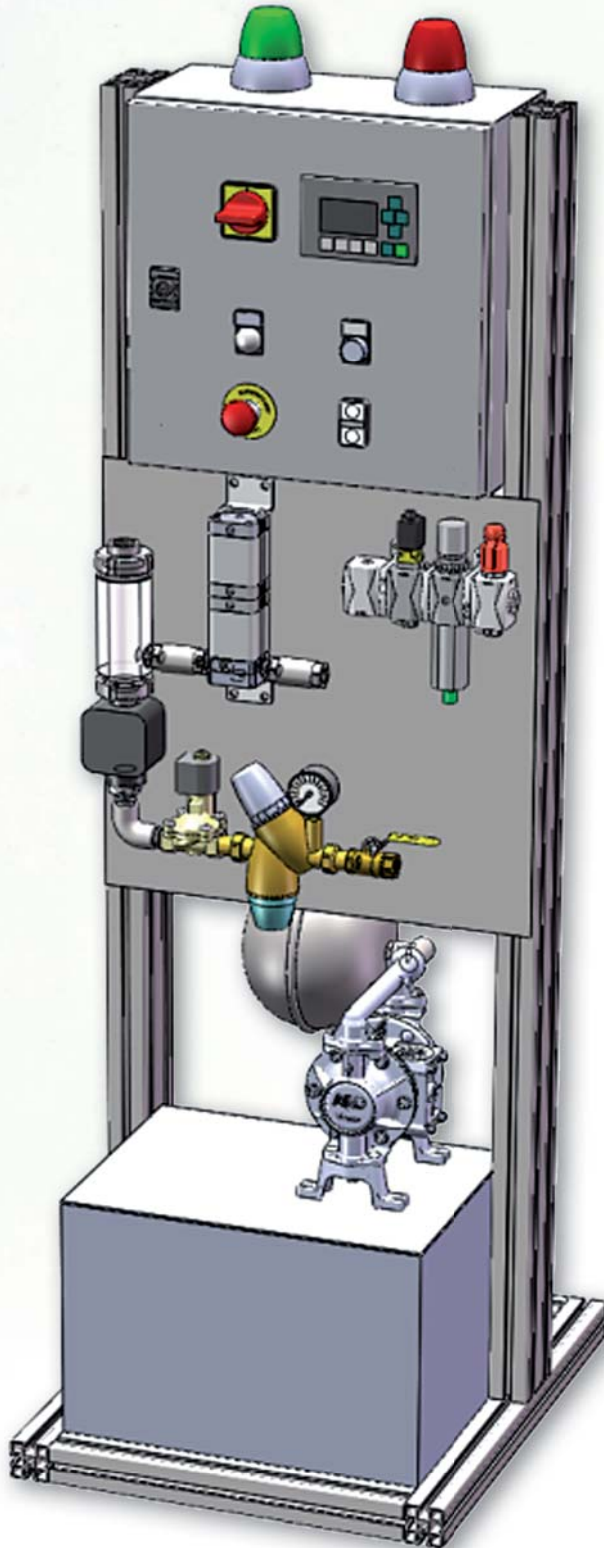

A completely automatic dosing system,
proportional and volumetric,
to prepare release agent at a constant
dilution in water.



SIST MIX MAUI

DESCRIPTION OF THE EQUIPMENT

The system is compact and its handling is easy and intuitive.

It consists of a structure realized with a frame having aluminum extruded profiles and a stainless steel panel.

On the structure the following features are installed:

- a stainless steel panel having on its top the electrical panel to run the plant and on its lower part the mixing unit.
- a stainless steel tank for the storage of the diluted release agent.
- a pneumatic pump on the upper part of the tank
- an expansion tank with a 5 liters capacity
- devices and valves for the operation and the management of the system

Electrical panel

It includes:

An interface panel for the operator having the following functions:

- Setting the dilution rate from 0.1 to 5%.
- Total and partial counter liter, with zeroing of the diluted product used
- Alarm metering pump blocked, for its breaking or when missing air
- Alarm failure water flow or breaking of water flow meter
- Reading messages with the possibility of three different languages

A sectioning counter of the power supply

A safety module for the interception of power sources

A pneumatic valve for the interception of the delivery pressure

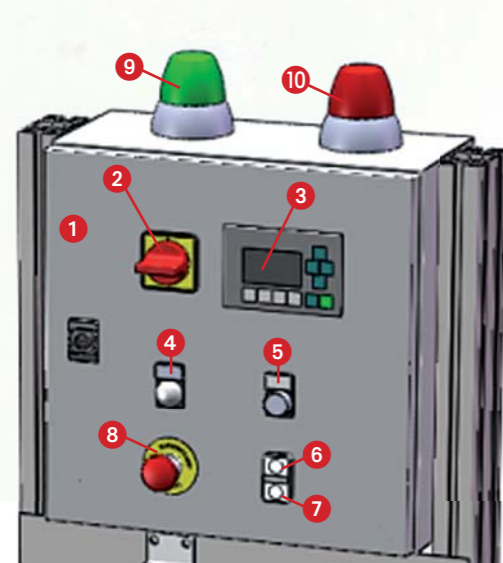

1. Electrical panel
2. Luminous main switch
3. Interface Panel for the user
 - ENTER button to confirm the settings
 - CLEAR button to clear the settings
 - ALR luminous button to reset each type of alarm
 - Functional buttons F1 - F5
 - Display to view settings and alarms
 - Buttons to move the cursor to increase or decrease values while setting
4. Man-Auto Selector
5. Signal lamp of the power applied
6. Luminous green button to start the mixing cycle
7. Hole of spare with cap
8. Luminous button for the insertion of the auxiliaries
9. Button to stop the cycle
10. Emergency button

Mixing group

It manages the mixing of the concentrate release agent with the water to supply the storage tank with diluted release agent.

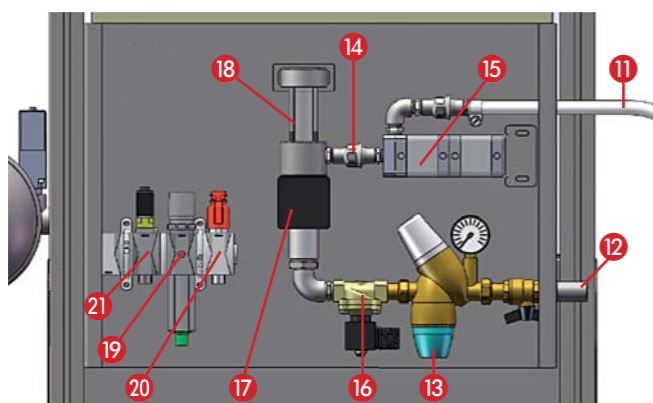

11. Tube two meters long for suctioning the concentrated release agent, completed with a one way valve and a filter
12. Ball valve for water connection (3-5 bars)
13. Water pressure regulator with manometer and filter
14. One way valve
15. Volumetric dosing pump
16. Solenoid valve water control
17. Electronic water flow meter
18. Transparent inspection
19. Air pressure regulator with pressure gauge
20. Connection with tap for air
21. Solenoid valve metering pump control

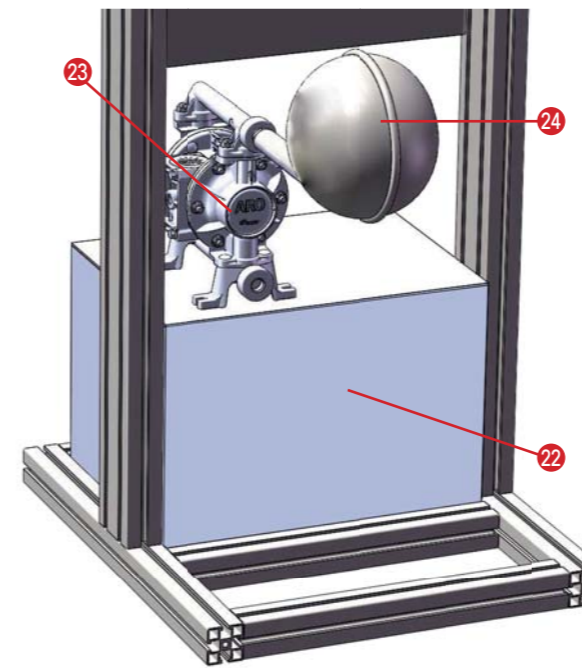

Storage tank for the diluted release agent

The stainless steel tank of the diluted has a capacity of 30 liters and a large inspection cover provided with a key lock.

This capacity avoids that a large amount of diluted product remains unused for a long time, situation that could cause a bacterial contamination or the formation of patinas on the surface of the diluted. It also facilitates a fast cleaning to avoid the spread of fungus and contamination.

The fresh mixing diluted product is the most powerful.

Above the storage tank, a pneumatic pump is installed with a flow rate of 40 l. / min. that is completed with an expansion tank of 5 liters capacity.

Inside the tank of the diluted there is an electronic level control system which manages the minimum and super maximum levels.

- 22. Storage tank
- 23. Pneumatic pump
- 24. Expansion tank

Operation

The operational principle is based on the proportionality between the passage of the water and the dosed concentrated product.

Thanks to an electronic flowmeter, that gives an accurate dosage regardless of the water flow, the dosing pump can supply till to 40 cc of concentrated product at each pulse.

The diluted product flows into a transparent inspection, then into the storage tank where a delivery pump delivers the product to the spraying system for the dies.

The amount of release agent to be diluted is handled by the operator that will set it up, depending on his needs, directly on the display of the control panel.

THE MAUI SYSTEM can prepare 40 liters of release agent diluted at a minute.

The electrical level control placed into the storage tank can manage:

- The minimum level, which gives its consent to prepare the amount of diluted release agent set by the operator
- The super maximum level, that prevents any overflowing of the diluted release agent out of the storage tank. The level height will be set up by the operator to a few centimeters above the amount of the diluted set.

In case that the diluted arrives at the super maximum level and the required amount cannot be produced, the system will remember the delivered dose and at the lowering of the level it will produce the missing amount to its achievement.

Benefits

- Automatic production of release agent with rigorously constant dilution thanks to the chance of calibrating the metering pump according to the density of the product.
- Easy programming through a micro processor
- Low maintenance due to its reliability and robustness
- Constant production and amount of the diluted release agent, predefined by the customer, depending on the needs of the case (dies start, press stop, frequent changes in dilution rate, etc.)

Connections

- Power supply 24 V cc
- Compressed air at 6 bar by an attack ¼ " female with 6 mm RILSAN® tube.
- Clean water, through a ½ female with a 15 mm tube

The MAUI SYSTEM must be strictly fixed at 30 cm. above the container of the concentrate

Dimensions

- Height 1.703mm. • Width 505 mm. • Depth 600 mm.

Accessories

- Sensor to be dipped into the container of the concentrate for its detection level, and equipped with an alarm activating when the product is about to end.
- Transducer to control the exact dosage of the metering pump.
- Safety check of the level of the diluted product with a super lowest alarm that manages the system and stops the spraying system of the dies.
- Adjustable pressure switch to control the correct delivery pressure of the diluted release agent.

ALWAYS REMEMBER THAT IT IS EXPENSIVE TO USING A FRAGILE AND UNRELIABLE DOSAGE SYSTEM

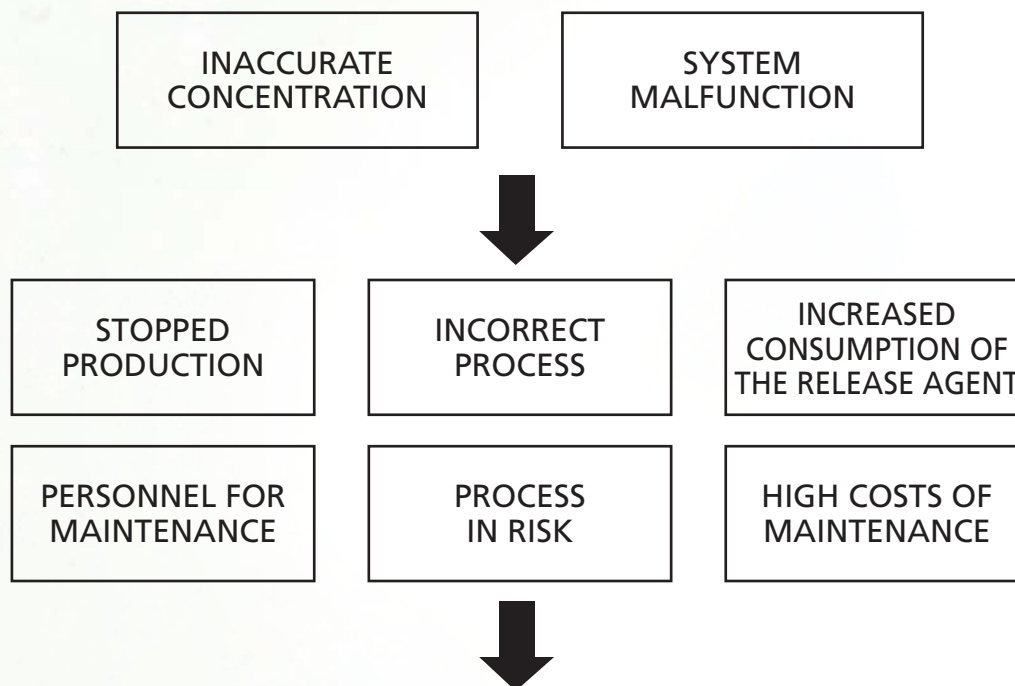

HIGH COSTS AND TROUBLES

REDUCE COSTS AND IMPROVE YOUR PROCESS WITH MAUI

Maintenance and use

To avoid particular maintenance use clean water and compressed air free oil and condensation.

USE ORIGINAL SPARE PARTS ONLY